



BLUEWATER AUTOMATION INC.

A TESSERA GROUP COMPANY

TEL: 416-291-9229 x6

EMAIL: info@bluewaterautomation.com

BLUEWATERAUTOMATION.COM

141 Reach Street Unit #5A
Uxbridge, ON L9P 1L3

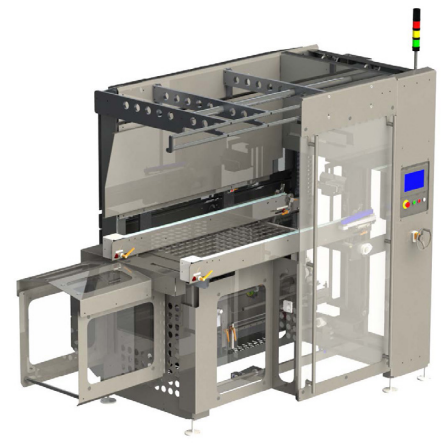

F16-T CASE FORMER

Our new “Clean” designs are not only suitable for wet environments but more importantly, were designed from the ground up to meet strict sanitary specifications. Our products are manufactured by a team of individuals specifically trained and familiar with food safety requirements including HACCP, AMI, 3A and others.

Our F16-T Case Former, compact in size, will automatically index in a Case Blank, confirm case integrity, positively fold all four bottom flaps and seal with pressure sensitive tape at rates up to 16 cases per minute.

COMPACT DESIGN CASE FORMER

SANITARY DESIGN

SMALL FOOTPRINT

*Also available
with Hot Melt
Glue Closure*

FEATURES:

- Stainless Steel Open Form Frame
- Easy Clean wash down design
- Centralized electrical and pneumatics
- Tape or Hot Melt Glue System Optional
- European Cantilevered ergonomics for separation of operator and maintenance access
- Reduced wear points extend run times between maintenance intervals
- Inline pass through product conveyor location improves line efficiencies
- Walk-in “no-guide” magazine facilitates Case blank replenishment
- Self-evident, quick lock adjustment points improve repeatability and speed of case size change overs
- Throughput speed optimizing system
- No tab Case blank separation
- Case blank “Integrity Test” station ensures case quality prior to forming
- Positive 2 side case opening vacuum shuttle
- Servo shuttle control
- Adjustable case squaring
- Adjustable for corrugated wall thickness
- Active 4 flap folding
- Full perimeter guarding package - including PSR approvals
- Extended run time Case blank magazine option
- Tool free Tape Head removal for tape roll changes
- PrimeLoc™ 2” Stainless Steel Tape Head
- Allen-Bradley PLC / HMI / Servo Control
- Festo Pneumatics



BLUEWATER AUTOMATION INC.

A TESSERA GROUP COMPANY

TEL: 416-291-9229 x6

EMAIL: info@bluewaterautomation.com

BLUEWATERAUTOMATION.COM

141 Reach Street Unit #5A
Uxbridge, ON L9P 1L3

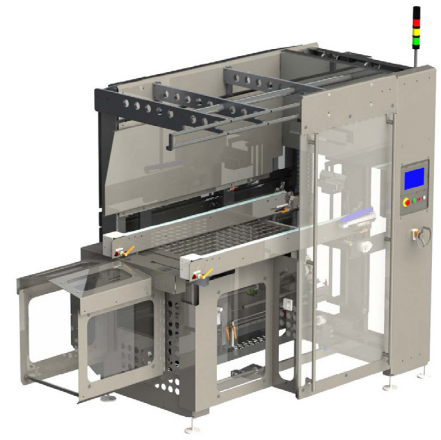

F16-T CASE FORMER



Allen-Bradley

by ROCKWELL AUTOMATION

FESTO

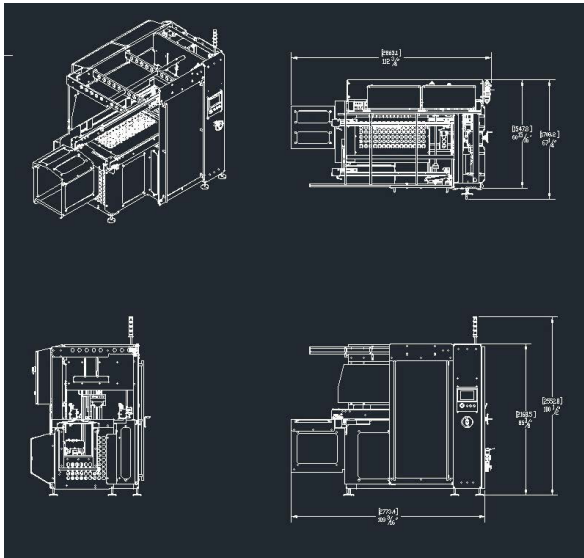

SPECIFICATIONS:

Case Size Range: L10" W6" D4" (minimum) / L18" W12" D8" (maximum)

- extended range package available

Machine Dimensions: L69" W55" D81"

Outfeed Height: D20" (minimum) / D24" (maximum)

Speed: Up to 16 case / min.

Controls: Allen-Bradley

Pneumatics: Festo

Servo: Allen-Bradley

Voltage: 480VAC, 3Ph + Others

Frame: Stainless Steel Open Form

Sub-assemblies: Stainless Steel, UHMW Plastics and Anodized Aluminum

Fasteners: Stainless Steel